

**INDUSTRIAL**

**QD Quiet Power**

# Air Compressor Manual



**Models:**

# TABLE OF CONTENTS

## PAGE

- 1      **Safety Guidelines - Definitions**  
**Before Using the Air Compressor**
- 2      **When Installing or Moving the Compressor**  
**Before Each Use**
- 3      **Follow Safety Precautions for Electrical Connection**  
**Plan Ahead to Protect Your Eyes, Hands, Face & Ears**  
**When Operating**
- 4      **Spraying Precautions**  
**Perform These Maintenance Operations**
- 5      **Typical Compressor Installation**  
**Glossary**
- 6      **Wiring**
- 7      **Starting the Compressor**
- 8      **Fully Packaged and QP Compressor Section**
- 9      **Troubleshooting Guide**
- 10     **Troubleshooting (Cont.)**

# SAFETY GUIDELINES - DEFINITIONS

Safety is a combination of common sense, staying alert and knowing how your compressor works. Read this manual to understand this compressor.



## DANGER

means if safety information is not followed someone **will** be seriously injured or killed



## WARNING

means if safety information is not followed someone **could** be seriously injured or killed



## CAUTION

means if safety information is not followed someone **may** be seriously injured or killed

# IMPORTANT SAFETY INSTRUCTIONS

## *Save these instructions*

Improper operation or maintenance of this product could result in serious injury and property damage. Read and understand all warnings and operation instructions before using this compressor.

## *Before using the air compressor*

### Things you should know

Air compressors are utilized in a variety of air system applications. Because air compressors and other components (hoses, connectors, air tools, spray guns, etc.) make up a high pressure pumping system, the following safety precautions should be observed at all times.

**Only persons familiar with these rules of safe operation should use the air compressor.**

1. Read the instruction manual carefully before attempting to assemble, disassemble or operate your system. Be thoroughly familiar with the controls and the proper use of the equipment.
2. Review and understand all safety instructions and operating procedures in this manual.
3. Review the maintenance methods for this compressor (See "Maintaining Your Compressor" section).

### Inspect your work area

1. Keep work area clean.
2. Cluttered areas and benches invite accidents. Floors must not be slippery from wax or dust.

### Inspect your compressor

1. To reduce the risk of injury from accidental starting, turn switch off and disconnect the power before checking it.
2. If any part is missing, bent or broken in any way, or any electrical part does not work properly, keep the compressor off and disconnected.
3. Check hoses for weak or worn condition before each use, making certain all connections are secure. Do Not use if defect is found.



## WARNING

Do not operate compressor if damaged during shipping, handling or use. Damage may result in bursting and cause injury or property damage.



## DANGER

This compressor is Not designed for and should not be used in breathing air applications.

## When installing or moving the compressor



### WARNING

This compressor is extremely top heavy. The compressor must be secured to the floor before operating to prevent equipment damage, injury or death. The compressor must be mounted on vibration pads. **Do Not** tighten bolts completely as this may cause stress to the tank welds.

#### To reduce the risk of a dangerous environment

1. Keep work area well lit.
2. Operate compressor in a well-ventilated area free from flammable liquids and vapors.
3. Operate compressor in a ventilated area so that compressor may be properly cooled and the surrounding air temperature will not be more than 100°F.
4. Never use a compressor in a wet environment.
5. Protect material lines and air lines from damage or puncture. Keep hose and wires away from sharp objects, chemical spills, oil, solvents and wet floors.



### WARNING

**Do Not** secure compressor with toggle bolts into drywall. Drywall sheeting or plaster will not support the weight of the compressor.

#### Note:

**Tank Outlet Size:** 30 Gallon Gas Drive - 1/2" NPT  
80 and 120 Gallon Electric - 3/4" NPT  
Duplex - 1" NPT

6. A minimum clearance of 18 inches between the compressor and a wall is required because objects could obstruct airflow.
7. The compressor should be located where it can be directly wired to a circuit breaker. The compressor should be wired by a qualified electrician.
8. Never store flammable liquids or gases in the vicinity of an operating compressor.
9. **Do Not** locate the compressor air inlet near steam, paint spray, sandblasting areas or any other source of contamination. The debris could damage the motor and pump.



### WARNING

Never use plastic (PVC) pipe for compressed air. Serious injury or death could result.



### CAUTION

Never use the shipping skid for mounting the compressor.



### NOTICE

This compressor is not intended for outdoor installation.



### WARNING

Never install a shut off valve between the compressor pump and tank. Personal injury and/or equipment damage could occur.

## Before each use

### Inspect your work area

1. Keep work area clean. Cluttered areas and benches invite accidents.
2. The floor must not be slippery from wax or dust.

### Inspect your compressor

1. To reduce the risk of injury from accidental starting, turn the switch off and disconnect power.
2. If any part is missing, bent or broken in any way, or any electrical part does not work properly, keep the compressor off and disconnect power. **Do Not** use if defect is found.
3. Check hoses for weak or worn condition before each use, making certain all connections are secure. **Do Not** use if a defect is found.

## ***Follow the safety precautions for electrical connections***

1. Follow all local electrical and safety codes, as well as the National Electric Code (NEC) and the Occupational Safety and Health Act (OSHA).
2. Wiring and fuses should follow electrical codes, current capacity and be properly grounded.
3. Protect wires from contact with sharp objects.



### **CAUTION**

All electrical connections should be made by a qualified electrician.

## ***Plan ahead to protect your eyes, hands, face and ears***

### **Dress for safety**

1. Wear safety glasses (meeting ANSI Z87.1 or in Canada CSA Z94.3-99) and use hearing protection when operating the unit. Everyday glasses are not safety glasses.
2. Wear shoes to prevent shock hazards.
3. Tie back long hair.

### **Pay attention to your hands**



### **WARNING**

Keep fingers away from running compressor. Fast moving and hot parts may cause injury and/or burns.



### **WARNING**

Be careful when touching the exterior of compressor, pump, motor and air lines; they may become hot enough to cause injury.



### **WARNING**

Never operate the compressor without a beltguard. The compressor can start automatically without warning. Personal injury or property damage could occur from contact with moving parts.



### **CAUTION**

The compressor may be hot even if the unit is stopped.



### **WARNING**

Use of a mask or respirator per chemical manufacturers' instructions may be necessary if there is a chance of inhaling toxic fumes. Read mask and respirator instructions carefully. Consult a safety expert if you are not sure about the use of certain masks or respirators.

## ***When operating***

1. Do not exceed the pressure rating of any component of the system.
2. Release pressure within the system slowly to prevent flying dust and debris.
3. If the equipment starts to abnormally vibrate, STOP the compressor immediately and check for the cause.



### **WARNING**

Never change the safety valve or pressure switch settings. Keep safety valve free from paint and other accumulations. See compressor specification decal for maximum operating pressure. Do not operate with the pressure switch set higher than the maximum operating pressure.

# TYPICAL COMPRESSOR INSTALLATION

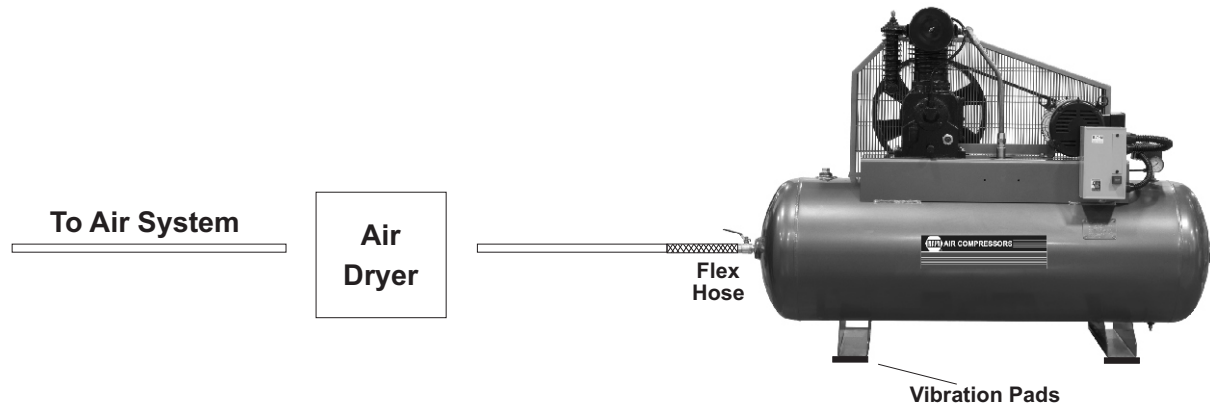

## GLOSSARY OF TERMS

### Air Filter

Porous element contained within a metal or plastic housing attached to the compressor cylinder head which removes impurity from the intake air of the compressor.

### Air Tank

Cylindrical component which contains the compressed air.

### Check Valve

Device which prevents compressed air from flowing back from the air tank to the compressor pump.

### Electric Motor

Device which provides the rotational force necessary to operate the compressor pump.

### Pressure Gauge

Device which shows the tank or regulated pressure of the compressed air.

### Pressure Switch

Device which automatically controls the on/off cycling of the compressor. It stops the compressor when the cut-off pressure in the tank is reached and starts the compressor when the air pressure drops below the cut-in pressure.

### PSI (Pounds per Square Inch)

Measurement of the pressure exerted by the force of air. The actual psi is measured by a pressure gauge on the compressor.

### Pump

Device which produces the compressed air with a reciprocating piston contained within a cylinder.

### Safety Valve

Device which prevents air pressure in the air tank from rising over a predetermined limit.

### Thermal Overload Switch

Device, integrated into the electric motor winding, which automatically "shuts off" the compressor if the temperature of the electric motor exceeds a predetermined limit.

## Spraying precautions



### WARNING

Never point a spray gun at yourself or any other person or animal. Accidental discharge may result in serious injury.

#### Reduce the risk of dangerous environment



### WARNING

Extreme caution should be taken when spraying flammable liquids as the spark from a motor or pressure switch may cause a fire or explosion. Ample ventilation must be provided.



### WARNING

Spray in a well ventilated area to keep fumes from collecting and causing serious injury and fire hazards.

1. **Do Not** spray in the vicinity of open flames or other places where a spark can cause ignition. **Do Not** smoke when spraying paint, insecticides, or other flammable substances.

#### Be informed about the materials you use

1. When spraying with solvents or toxic chemicals, follow the instructions provided by the chemical manufacturer. Consult a safety expert if unsure about the use of masks or respirators.
2. If the material you intend to spray contains trichloroethane and methylene chloride, do not use accessories that contain aluminum or galvanized materials, as these chemicals can react with galvanized components causing corrosion and weakening equipment. Use stainless steel accessories.

## Perform these maintenance operations

1. Do regular maintenance; keep all nuts, bolts, and screws tight, to be sure equipment is in safe working condition.
2. Inspect tank yearly for rust, pin holes or any other imperfections that could cause it to become unsafe.



### WARNING

NEVER attempt to repair or modify a tank! Welding, drilling or any other modification will weaken the tank resulting in damage from rupture or explosion. Always replace worn, cracked or damaged tanks.

3. Clean electrical equipment with an approved cleaning agent, such as a dry, non-flammable cleaning solvent.

4. Drain tanks of moisture after each day's use. If unit will not be used for awhile, it is best to leave the drain cock open until such time as it is to be used. This will allow moisture to completely drain out and help prevent corrosion of inside of tank.
5. Always disconnect from power source before working on or near a motor, or its connected load. If power disconnect point is out-of-sight, secure it in the "OFF" position and tag it to prevent unexpected application of power.



### WARNING

Disconnect power and depressurize system before servicing air compressor. Slightly open drain cock after shutting off compressor.

#### Daily

Check oil level at sight glass. Oil level should be 1/2 to slightly higher in the oil sight glass.

Drain moisture from tank.

Verify the pressure switch unloader is working by listening for a brief hissing sound when the compressor shuts off.

Visually check the compressor for loose parts, excessive noise or vibration. Tighten any necessary part.

#### Monthly

(Make sure the main power is off.) Check the belts for tension. Belts should not move up and down when the compressor runs and when stopped, should not have more than 1/2 in of play when depressed. Be careful not to over tighten belts during adjustment.

Remove and check air filter, replace if necessary.

Change oil every 3 months or 300 hours. A compressor grade non-detergent oil should be used. **Part # 82-6020**

# WIRING



## WARNING

ALL ELECTRICAL WIRING SHOULD BE DONE BY A QUALIFIED ELECTRICIAN

### General Information

Adequate wiring and motor protection should be provided for all stationary compressors. Wiring used for other machinery should not be used. A qualified electrician familiar with local electrical codes in your area should be used. Size supply wiring per NEC (National Electric Code) requirements.

Incoming power should be connected to L1 and L2 at the Top of the Magnetic Starter.

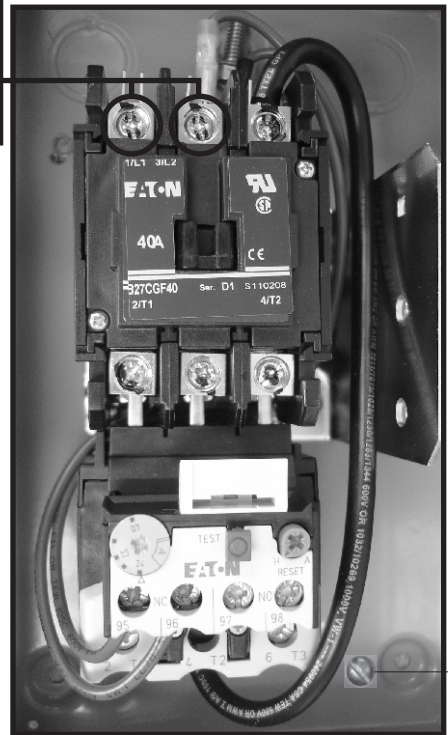

Ground

Single Phase



## WARNING

Electrical connections must be properly grounded. Ground connections should be connected at the grounding screw.



## CAUTION

Overheating, short circuiting and fire damage will result from inadequate wiring.

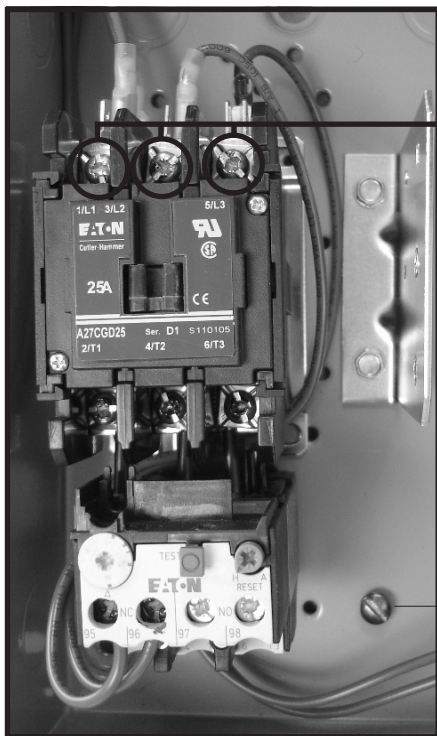

Incoming power should be connected to L1, L2 & L3 at the Top of the Magnetic Starter.

**DO NOT MAKE CONNECTIONS AT THE PRESSURE SWITCH**

## DUPLEX

Power should be brought into the left hand starter. Do not bring power to both starters.

Ground

Three Phase



# STARTING THE COMPRESSOR

Prior to running the compressor, check the following items:

Crankcase oil - Make sure the sight glass shows  $\frac{1}{2}$  full or slightly above.

Make sure all rags, tools, oil, etc. are away from the unit.

Open the air system to free it of any pressure.

Switch the compressor on for a few revolutions to make sure the rotation is correct. Correct rotation is clockwise when facing the sight glass on the pump.

Operate the compressor for a few minutes unloaded (air system open) then allow the compressor to pump up. Make sure the electrical pressure switch properly switches off the compressor according to the setting desired. (175 PSI Max)



## CAUTION

Make sure the pressure in the tank does not exceed its rating. Maximum of 175 psi. If the pressure gauge indicates a pressure that is higher than these maximum pressures, shut off compressor immediately and call 866-869-3114.

### *(Gas Drive Models)*

**PLEASE REFER TO YOUR ENGINE OPERATION MANUAL FOR PROPER STARTING INSTRUCTIONS.**

**NAPA GASOLINE DRIVEN COMPRESSORS ARE EQUIPPED WITH A COLD START VALVE FOR LOADLESS STARTS. THERE IS NO NEED TO MANUALLY UNLOAD AIR PRESSURE.**

### *Battery Connection Instructions for Electric Start Engines*

Note: Make sure to follow instructions carefully to avoid a short and possible damage to the starter solenoid and/or battery.

1. Connect the positive (+) terminal on the battery to the starter solenoid.
2. Connect the negative (-) terminal on the battery to an engine mounting bolt or other acceptable ground connection.

Always connect the positive(+) battery cable to the starter solenoid before connecting the negative(-) battery cable.

### **NUMBER 2 WIRE OR LARGER IS REQUIRED**

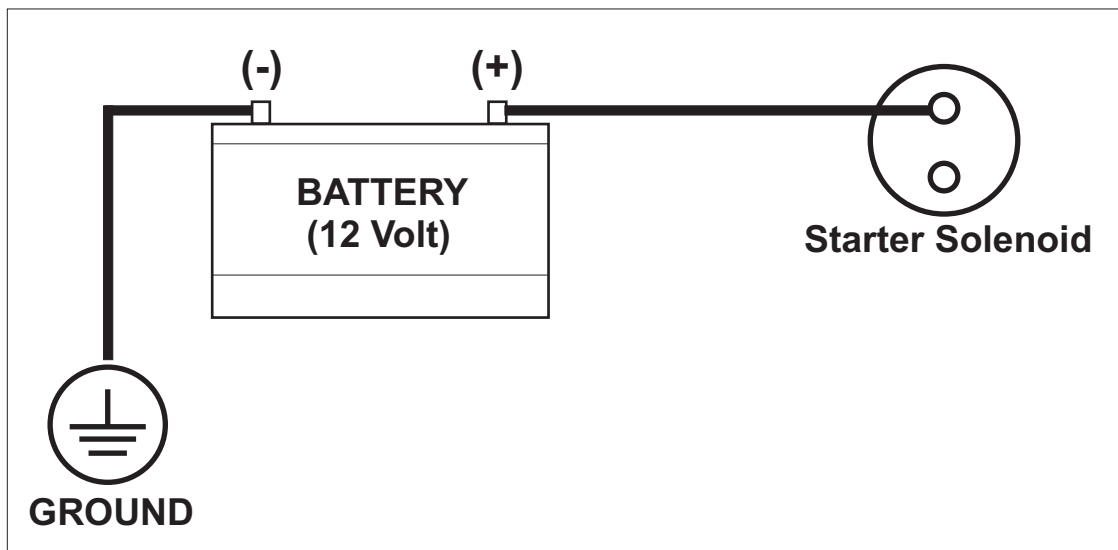

## QP Compressors

The QP comes equipped with sound attenuating enclosure. For maintenance, the canopy and side foam pieces will need to be removed.

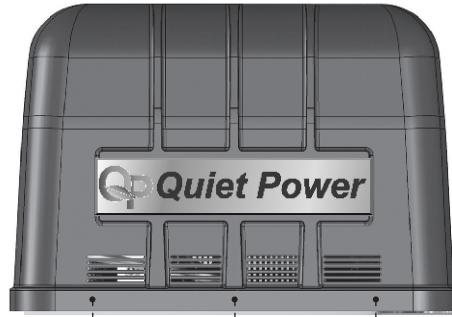

To remove the canopy, simply remove the 6 fasteners and lift the canopy straight up and off.

## QP and Fully Packaged Compressors

QP and fully packaged models come equipped with low oil level switches and automatic tank drains. The QP models also include protection against over-heating.

### Low Oil Level Switch

The function of the low oil level switch is to keep the air compressor from starting if the oil level drops beyond a certain point.

For compressors outfitted with the low oil level switch, the oil should be in the top 1/3 of the oil sight glass.

When changing or adding oil, it is important to remove the Oil Vent Plug to allow for the oil to flow completely into the switch.

(Please Note: If overfilled, oil will flow out of the oil vent hole)

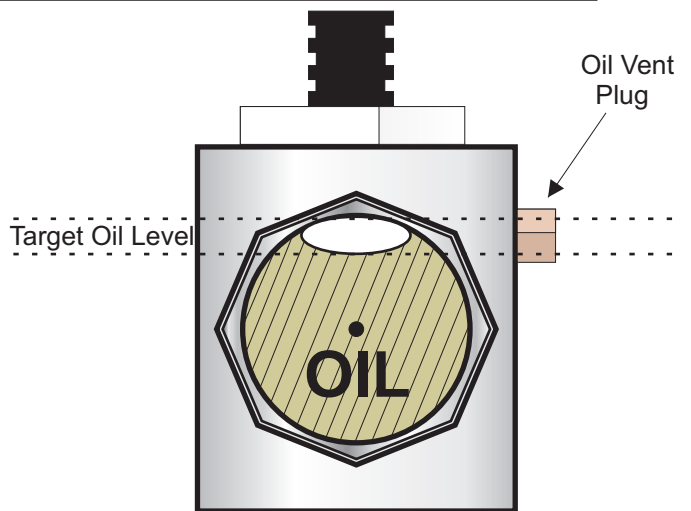

### Thermal Protection - QP Models

If the cooling fan were to fail or internal temperature were to reach 170°F the QP models are outfitted with a thermal fuse.

When tripped, the fuse can be reset. The canopy will need to be removed to reset the thermal fuse.



Press to  
Reset

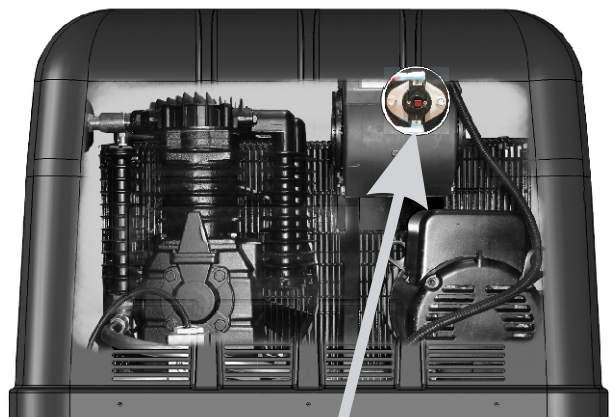

Location of Fuse  
(Inside Canopy  
Behind Fan)

# TROUBLESHOOTING GUIDE

<p>Low discharge pressure</p>	<ol style="list-style-type: none"> <li>1. Compressor too small for application</li> <li>2. Air leaks</li> <li>3. Restricted intake air</li> <li>4. Blown gasket(s)</li> <li>5. Broken or misaligned valves</li> </ol>	<ol style="list-style-type: none"> <li>1. Reduce air demand or use a compressor with more air capacity.</li> <li>2. Listen for air leaks. Apply a soap solution to all fittings and connections. Bubbles will form at points of leakage. Tighten or replace fittings or connections.</li> <li>3. Clean or replace air filter.</li> <li>4. Replace necessary gaskets.</li> <li>5. Remove head and inspect for broken or misaligned valves. Replace valves, if necessary.</li> </ol> <p><b>⚠ CAUTION</b> Install a new head gasket each time head is removed</p>
<p>Excessive noise “knocking”</p>	<ol style="list-style-type: none"> <li>1. Loose drive pulley or flywheel</li> <li>2. Low on oil</li> <li>3. Worn connecting rod or connecting rod bearing</li> <li>4. Noisy check valve</li> </ol>	<ol style="list-style-type: none"> <li>1. Tighten drive pulley or flywheel bolt.</li> <li>2. Check for proper oil level. Low or dirty oil may cause bearing damage.</li> <li>3. Replace connecting rod and/or connecting rod bearings.</li> <li>4. Replace check valve.</li> </ol> <p><b>⚠ DANGER</b> Do not remove check valve with air pressure in tank</p>
<p>Excessive oil carryover</p>	<ol style="list-style-type: none"> <li>1. Worn piston rings</li> <li>2. Restricted intake air</li> <li>3. Too much oil in compressor</li> <li>4. Incorrect oil viscosity</li> </ol>	<ol style="list-style-type: none"> <li>1. Replace with new piston rings.</li> <li>2. Clean or replace air filter.</li> <li>3. Drain oil to proper oil level.</li> <li>4. Use a quality non-detergent 30 or 40wt oil specified for each model (Page 4).</li> </ol>
<p>Water in tank and/or discharge line</p>	<ol style="list-style-type: none"> <li>1. Normal. Amount of water will increase as humidity in the air increases.</li> </ol>	<ol style="list-style-type: none"> <li>1. Drain tank at least once per day.</li> <li>2. Add an inline filter to reduce moisture in in the air line.</li> </ol>
<p>Will not run or motor hums</p>	<ol style="list-style-type: none"> <li>1. Low voltage</li> <li>2. Malfunctioning pressure switch</li> <li>3. Malfunctioning check valve</li> </ol>	<ol style="list-style-type: none"> <li>1. Check voltage with volt meter across both legs of incoming power. Check reset button on motor.</li> <li>2. Repair or replace pressure switch.</li> <li>3. Replace check valve or pressure switch.</li> </ol> <p><b>⚠ DANGER</b> Do not remove check valve with air pressure in tank</p>
<p>Breaker or reset repeatedly trips</p>	<ol style="list-style-type: none"> <li>1. Incorrect breaker size</li> <li>2. Low voltage</li> <li>3. Malfunctioning motor</li> <li>4. Loose electrical connections</li> <li>5. Malfunctioning pressure switch</li> <li>6. Malfunctioning check valve</li> </ol>	<ol style="list-style-type: none"> <li>1. Make sure the breaker is sized properly. See page 6 in this manual.</li> <li>2. Check voltage with volt meter across both legs of incoming power.</li> <li>3. Replace motor.</li> <li>4. Check all electrical connections.</li> <li>5. Adjust or replace pressure switch.</li> <li>6. Replace check valve.</li> </ol> <p><b>⚠ DANGER</b> Do not remove check valve with air pressure in tank</p>
<p>Tank does not hold pressure when not running and shut off valve is closed</p>	<ol style="list-style-type: none"> <li>1. Malfunctioning check valve</li> <li>2. Loose fittings or connections</li> <li>3. Crack or pin hole in tank</li> </ol>	<ol style="list-style-type: none"> <li>1. Replace check valve.</li> </ol> <p><b>⚠ DANGER</b> Do not remove check valve with air pressure in tank</p> <ol style="list-style-type: none"> <li>2. Tighten or replace fittings or connections.</li> <li>3. Replace tank. Do not attempt to repair tank.</li> </ol>

## TROUBLESHOOTING GUIDE (Continued)

<p>Pressure switch un-loader constantly leaking air</p>	<p>1. Malfunctioning check valve</p>	<p>1. Replace check valve if unloader bleeds constantly.</p> <p><b>⚠ DANGER</b> Do not remove check valve with air pressure in tank</p>
<p>Pressure switch not unloading</p>	<p>1. Malfunctioning pressure switch</p>	<p>1. Replace pressure switch if it does not release air pressure briefly when unit shuts off.</p> <p><b>⚠ DANGER</b> Do not remove pressure switch with air pressure in tank</p>
<p>Excessive vibration</p>	<p>1. Improper installation 2. Loose belts 3. Misaligned flywheel or drive pulley</p>	<p>1. Make sure unit is mounted on a level surface with vibration pads. 2. Replace belts. Align and tighten properly. 3. Align flywheel and drive pulley.</p>
<p>Overheating</p>	<p>1. Compressor too small for application 2. Cooling surfaces dirty 3. Improper cooling</p>	<p>1. Reduce air demand or use a compressor with more air capacity. 2. Clean all cooling surfaces of dirt and dust. 3. Install compressor in an area with adequate cool dry air.</p>
<p>Will Not Start (Elite and QP)</p>	<p>1. Unit Low on Oil 2. Exhaust Fan Not Working</p>	<p>1. Add Oil to Proper Level 2. <b>Reset Thermal Overload</b></p>

# Warranty Statement

The Company warrants that the Equipment manufactured by it and delivered hereunder shall be free from defects in material and workmanship for a period of twelve (12) months from the date of initial start-up, or eighteen (18) months from the date of shipment from the manufacturer, whichever occurs first. The foregoing warranty period shall apply to all Equipment, except for the following: (A) all two stage reciprocating stationary models are warranted for the earlier of twenty-four (24) months from the date of initial operation or thirty (30) months from date of shipment from the manufacturer. (B) Replacement parts will be warranted for three (3) months from the date of shipment from the manufacturer. Should the failure to conform to this warranty be reported in writing to the Company within said period, the Company shall, at its option, correct such non-conformity by suitable repair to such Equipment, or furnish a replacement part F.O.B point of shipment, provided that the Purchaser has installed, maintained, and operated such Equipment in accordance with good industry practices, and has complied with specific recommendations of the Company. Accessories and equipment furnished by the Company, but manufactured by others, shall carry whatever warranty the manufacturer conveyed to the Company and which can be passed on to the Purchaser. The Company shall not be liable for any repairs, replacements, or adjustments to the Equipment, or any costs of labor performed by the Purchaser without the Company's prior written approval.

The Company makes no performance warranty unless specifically stated within its proposal, and the effects of corrosion, erosion, and normal wear and tear are specifically excluded from the Company's warranty. In the event performance warranties are expressly included, the Company's obligation shall be to correct in the manner and for the period of time provided above

This warranty does not apply to electric motors or gasoline engines. These are covered by the Original Manufacturer's Warranty and should be returned (by the customer) to their authorized service center for service..

THE COMPANY MAKES NO OTHER WARRANTY OR REPRESENTATION OF ANY KIND WHATSOEVER, EXPRESSED OR IMPLIED, EXCEPT THAT OF TITLE, AND ALL IMPLIED WARRANTIES OF MERCHANTABILITY AND FITNESS FOR A PARTICULAR PURPOSE, ARE HEREBY DISCLAIMED. THIS WARRANTY SUPERSEDES ALL PREVIOUS WARRANTY STATEMENTS.

Correction by the Company of non-conformities, whether patent or latent, in the manner and for the period of time provided above, shall constitute fulfillment of all liabilities of the Company and its distributors for such non-conformities with respect to, or arising out of such Equipment.

#### LIMITATION OF LIABILITY

THE REMEDIES OF THE PURCHASER SET FORTH HEREIN ARE EXCLUSIVE, AND THE TOTAL LIABILITY OF THE COMPANY, ITS DISTRIBUTORS AND SUPPLIERS WITH RESPECT TO CONTRACT OR THE EQUIPMENT AND SERVICES FURNISHED IN CONNECTION WITH THE PERFORMANCE OR BREACH THEREOF, OR FROM THE MANUFACTURE, SALE, DELIVERY, INSTALLATION, REPAIR OR TECHNICAL DIRECTION COVERED OR FURNISHED UNDER CONTRACT, WHETHER BASED ON CONTRACT, WARRANTY, NEGLIGENCE, INDEMNITY, STRICT LIABILITY OR OTHERWISE, SHALL NOT EXCEED THE PURCHASE PRICE OF THE EQUIPMENT UPON WHICH SUCH LIABILITY IS BASED.

THE COMPANY, ITS DISTRIBUTORS AND ITS SUPPLIERS SHALL IN NO EVENT BE LIABLE TO THE PURCHASER, ANY SUCCESSORS IN INTEREST, OR ANY BENEFICIARY OR ASSIGNEE OF THE CONTRACT FOR ANY CONSEQUENTIAL, INCIDENTAL, INDIRECT, SPECIAL OR PUNITIVE DAMAGES ARISING OUT OF THIS CONTRACT OR ANY BREACH THEREOF, OR ANY DEFECT IN, OR FAILURE OF, OR MALFUNCTION OF THE EQUIPMENT, WHETHER OR NOT BASED ON LOSS OF USE, LOST PROFITS OR REVENUE, INTEREST, LOST GOODWILL, WORK STOPPAGE, IMPAIRMENT OF OTHER GOODS, LOSS BY REASON OF SHUTDOWN OR NON-OPERATION, COST OF PURCHASE OF REPLACEMENT POWER, OR CLAIMS OF PURCHASER OR CUSTOMERS OF PURCHASER FOR SERVICE INTERRUPTION, WHETHER OR NOT SUCH LOSS OR DAMAGE IS BASED ON CONTRACT, WARRANTY, NEGLIGENCE, INDEMNITY, STRICT LIABILITY OR OTHERWISE.

**Atlas Copco Compressors**

1800 Overview Drive  
Rock Hill, SC 29730  
866-869-3114